

ACQUAVITE		Poltroncina		Lounge chair	
ACQUAVITE		Ottomana		Ottoman	
CELESTIA		Sedia esterno		Outdoor chair	
SANPOLO		Poltroncina		Lounge chair	
SANPOLO		Divanetto		Sofa	
SANPOLO		Tavolino		Coffee table	
RIALTINA	Braccioli	Gambe legno		Armrests	Wooden legs
RIALTINA	Braccioli	Slitta metallo		Armrests	Metal sled
RIALTINA	Braccioli	4 Razze		Armrests	4 Star Swivel Base
RIALTINA	Braccioli	5 Razze		Armrests	5 Star Swivel Base
RIALTINA	Seduta	Gambe legno		Armchair	Wooden legs
RIALTINA	Seduta	Slitta metallo		Armchair	Metal sled
RIALTINA	Seduta	4 Razze		Armchair	4 Star swivel Base
RIALTINA	Seduta	5 Razze		Armchair	5 Star swivel Base
CAORLINA	Sedia	Imbottita	Chair	Padded	
CAORLINA	Sedia	Paglia di Vienna		Chair	Woven cane
CAORLINA	Sedia	Multistrato	Chair	Plywood	
TAXI	C	Sedia	Chair		
TAXI	L	Poltroncina	Lounge chair		
TAXI	S	Sgabello	Stool		
PARÓN	Tavolo fisso	Metallo	Fixed table	Metal Base	
PARÓN	Tavolo fisso	Legno	Fixed table	Wooden Base	
PARÓN	Tavolo allungabile		Metallo	Extendable table	
PARÓN	Tavolo allungabile		Legno	Extendable table	
CIACOLA	Tavolo Bar tondo		3 Gambe	Round Bar table	
CIACOLA	Tavolo Bar quadrato		4 Gambe	Square Bar table	
CIACOLA	Tavolo Bar alto		3 Gambe	Round High table	
CIACOLA	Tavolo Pranzo	Dining Table			
PALINA	R	Tavolo rettangolare		Rectangular table	
PALINA	C	Tavolo circolare		Round table	
PALINA	O	Tavolo ovale	Oval table		
PALINA	Tavolo monogamba		Single leg table		

VD

P 7			Azienda			
P 15			Company Profile			
P 30	ACQUAVITE	Poltroncina Ottomana		Lounge chair Ottoman		
P 40	CELESTIA	Sedia esterno		Outdoor chair		
P 48	SANPOLO	Poltroncina Divanetto		Lounge chair Sofa		
P 60	RIALTINA	Tavolino Braccioli Braccioli Braccioli	Gambe legno Slitta metallo 4 Razze	Coffee table Armrests Armrests Armrests	Wooden legs Metal sled 4 Star Swivel Base	
		Braccioli	5 Razze	Armrests	5 Star Swivel Base	
		Seduta Seduta Seduta	Gambe legno Slitta metallo 4 Razze	Armchair Armchair Armchair	Wooden legs Metal sled 4 Star swivel Base	
		Seduta	5 Razze	Armchair	5 Star swivel Base	
P 68	CAORLINA	Sedia Sedia Sedia	Imbottita Paglia di Vienna Multistrato	Chair Chair Chair	Padded Woven cane Plywood	
P 74	TAXI	C L S	Sedia Poltroncina Sgabello	Chair Lounge chair Stool		
P 80	PARÓN	Tavolo fisso Tavolo fisso Tavolo allungabile	Metallo Legno	Fixed table Fixed table Metallo	Metal Base Wooden Base Extendable table	
		Tavolo allungabile		Metal Base Legno	Extendable table	
P 90	CIACOLA	Tavolo Bar tondo Tavolo Bar quadrato	3 Gambe	Wooden Base Round Bar table 4 Gambe	3 Legs Square Bar table 4 Legs	
		Tavolo Bar alto Tavolo Pranzo R	3 Gambe Dining Table Tavolo rettangolare	Round High table	3 Legs	
P 96	PALINA	C O Tavolo monogamba	Tavolo circolare Tavolo ovale	Round table Oval table Single leg table	Rectangular table	
P 104/111		Dati tecnici	Technical data			
P 112/115		Finiture	Finishes			
P 116/123		Visualizzazioni	Renderings			

VENEDIA



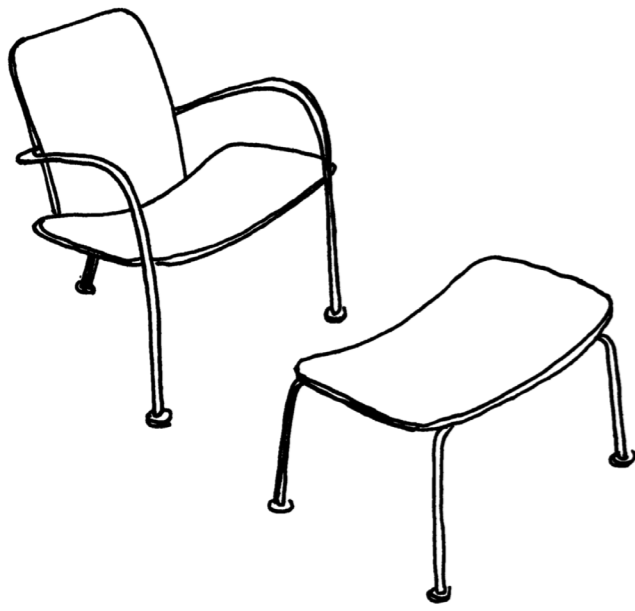

→ IT

Venedia, nome antico della città di Venezia, è situata a Concordia Sagittaria, proprio a metà strada tra il Veneto ed il Friuli Venezia Giulia, territorio storicamente aperto al mondo.

Venedia nasce per interpretare in chiave contemporanea l'eleganza, la preziosità e la storia della Serenissima, sfruttando un saper fare e una cultura produttiva unici al mondo, quella del Triveneto. I suoi arredi uniscono l'essenzialità e la tecnicità di una proposta Contract con la sapienza artigianale, che applicata ad ogni dettaglio arricchisce e nobilita il risultato finale.

Con la consapevolezza della tradizione veneziana e dei suoi territori limitrofi, i prodotti Venedia sono il risultato di sviluppi creativi rispettosi della storia, della cultura, dell'artigianato e della conoscenza affermatasi sapientemente nei secoli. Il saper fare e la bellezza sono il binomio che riecheggia tra le calli della città lagunare e Venedia incarna questa nuova declinazione del design inserita in una storia di tradizione e competenza. I valori e le tradizioni che caratterizzano il nostro territorio sono stati raccolti e ogni giorno riscoperti al fine di offrire una visione e una manifattura del Made in Italy originale e riconoscibile al pubblico. Design non fine a se stesso ma come innovatore della tradizione e della tecnologia. Innovare vuol dire riscoprire il passato, comprenderlo e riproporlo con i moderni strumenti del progetto. Attenta a tutti gli aspetti legati all'ergonomia, alla sicurezza e alla durabilità, Venedia si affida a laboratori specializzati e accreditati per verificare che i suoi prodotti rispecchino i principi prestazionali stabiliti da standard europei o internazionali. L'impatto dell'operato dell'azienda sull'ambiente che la circonda è di fondamentale importanza e ogni progetto Venedia prende in esame tutti gli aspetti più cruciali per rispettare l'ecosistema, a partire dal fragile territorio in cui insistiamo: Venezia.









Venedia, ancient name for the city of Venice, is located in Concordia Sagittaria, halfway between the regions of Veneto and Friuli Venezia Giulia, a land which historically has always been open to the world. Venedia is born to explain the elegance, fineness and history of “La Serenissima” (The Republic of Venice) with a contemporary twist, taking advantage of a Know-How and a production culture that is unique in the world, that of the “Three Venices” Area. Its products combine the simplicity and the technical nature of a contract design with the craftsmanship that is applied to every detail, ennobling the final result. With the awareness of the Venetian tradition and its neighbouring territories, Venedia’s products are the result of creative developments respectful of history, culture, artisan skill and knowledge that has wisely established itself over the centuries.

The Know-How and the Beauty are the combination that echoes in the streets of the lagoon city and Venedia embodies this new declination of design inserted in a history of tradition and competence. The values and tradition that characterize our territory have been collected and rediscovered every day in order to offer an original and intelligible vision and manufacture of “Made in Italy” to the public. Design not as an end in itself but rather as an innovator of tradition and technology. Innovating means rediscovering the past, understanding it and reproposing it with the modern tool of the project.

Attentive to every aspect related to ergonomics, safety and durability, Venedia relies on specialized and accredited laboratories to verify that the given products all follow the performance requirements established by European or International standards. The impact of our work on the environment around us is of fundamental importance. Each of the projects examines all the most crucial aspects to respect the ecosystem, starting with the area that we insist in: Venice.

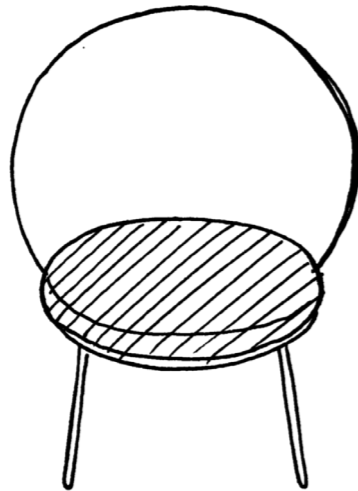







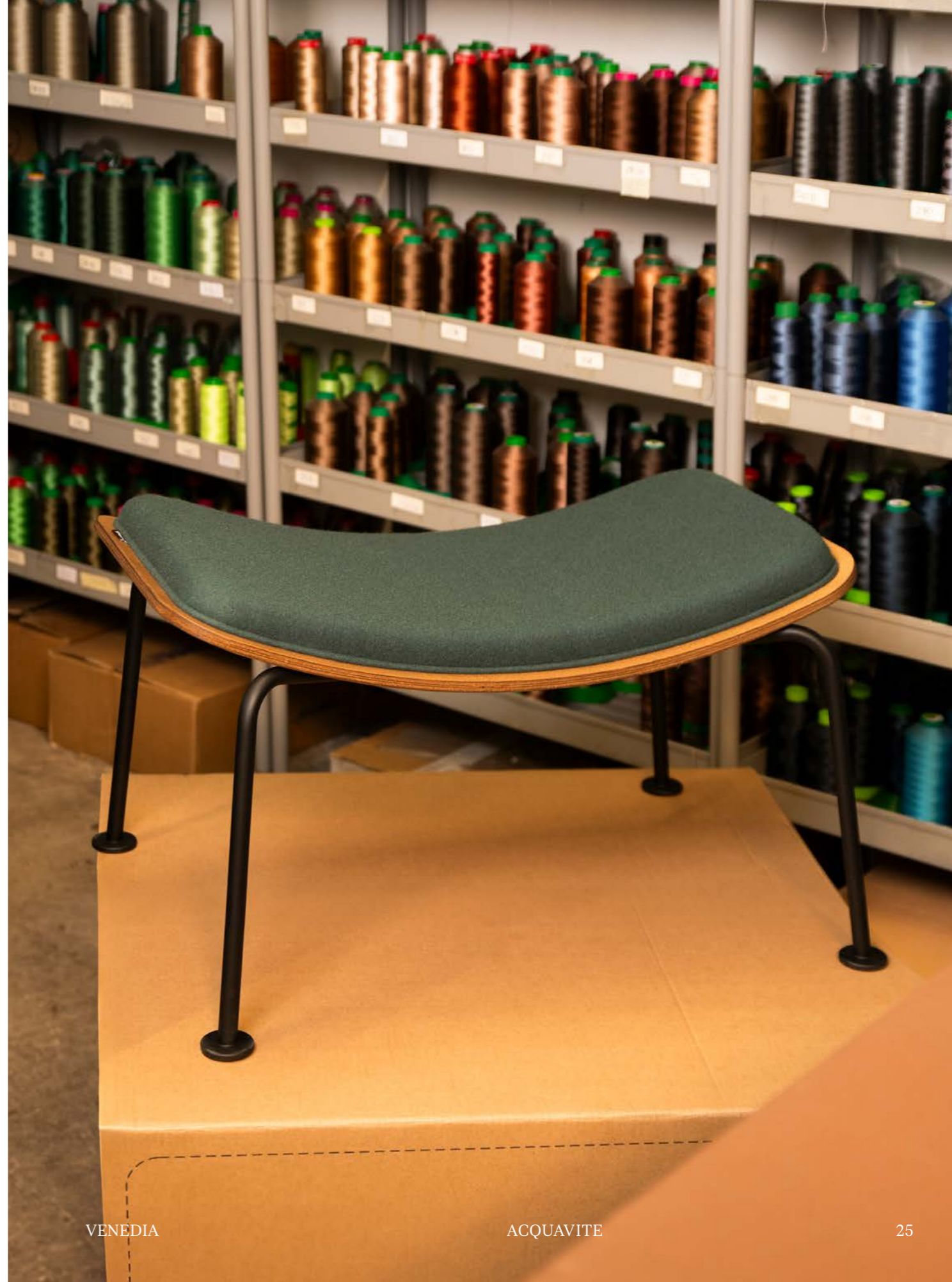





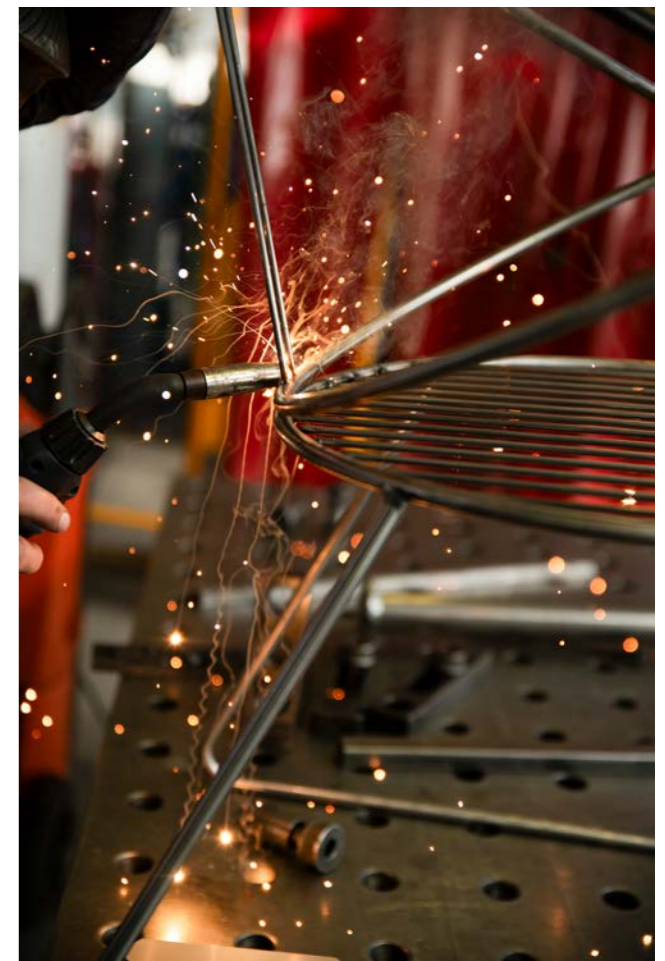

→ IT Due ampie scocche in multistrato curvato impiallacciato frassino dialogano in modo imprevisto con un telaio in tubolari d'acciaio che sembrano muoversi liberamente nello spazio. Danno forza all'immagine tre gambe che terminano in generosi piedini. Nasce così la seduta Acquavite, una poltroncina poco ingombrante per i momenti di riflessione e relax che dona carattere allo spazio in cui è collocata. Disponibile in legno naturale o tinto oppure con dei cuscini, si accompagna con un comodo ottomano che può fungere da poggiapiedi o da panchetta monoposto. Seduti comodamente con i piedi alzati, questa seduta è perfetta per sorseggiare una bevanda calda o fredda.

→ EN Two wide shells in ash-veneered plywood interact in an unexpected way with a tubular steel frame that seems to move freely in space. Three legs that end in generous feet give strength to the image.

Thus Acquavite was born, a space-saving armchair for moments of reflection and relaxation that gives character to the space in which it is placed. Available in either natural or tinted wood, with or without cushions, it is accompanied by a comfortable ottoman that can act as a footrest or single-seater bench. Leisurely sitting with the feet raised, this armchair is perfect for sipping a hot or cold beverage.











→ IT Celestia è una poltroncina in filo metallico pensata per gli spazi outdoor di bar e ristoranti, nata dalla volontà di trovare un punto d'incontro tra contemporaneità e classicità. È caratterizzata da due ampie volute che, partendo dalla parte inferiore dello schienale, arrivano a descrivere i braccioli. Il filo metallico acquista così morbidezza ed eleganza. La sedia prende il nome dalla piazza omonima, Campo de la Celestia, uno spiazzo tranquillo dove è possibile respirare la Venezia autentica.

→ EN Celestia is a metal wire armchair designed for the outdoor spaces of bars and restaurants, born from the desire to find a meeting point between contemporaneity and classicism. Its peculiarity lies on two spirals that, starting from the lower part of the backrest, follow along to describe the armrests. The metal wire thus acquires softness and elegance. The chair takes its name from the namesake square "Campo de la Celestia", a tranquil open space where you can feel the authentic Venice.









→ IT Sanpolo è una famiglia di sedute imbottite per l'attesa composta da poltroncina lounge e divanetto due posti. Seduta e schienale, dalle forme perfettamente circolari, si innestano l'uno nell'altra dando vita a prodotti caratterizzati da forme semplici. Il suo spiccato carattere si esprime grazie ad una forzatura delle proporzioni a favore dello schienale, che abbraccia e nobilita la seduta. Disponibili con schienale in legno curvato o interamente imbottite e rivestite, si completano grazie al tavolino basso con il quale vanno a delineare un armonioso salottino d'attesa. Il sestiere centrale della città presta il nome a questa giocosa collezione.

→ EN Sanpolo is a collection of upholstered seats composed of lounge chairs and two-seater sofas, perfect for lobbies and waiting areas. The seat and the backrest, with their circular shapes, are intertwined one another to create the simplicity yet elegance of the product. The forcing of the proportions in favour of the backrest expresses its strong character, embracing and ennobling the seat. Available with either a veneered wooden or upholstered backrest, the collection is tied together by a low coffee table, making it perfectly suitable for a comfortable waiting area. The central district of the city gives its name to this joyful collection.













→ IT Poltroncina imbottita dai lineamenti sottili e decisi ma con imbottiture morbide e confortevoli. Disponibile nelle varianti con e senza braccioli, la famiglia si arricchisce di diverse basi per ogni occasione: la slitta o la base girevole adatta agli spazi ibridi dell'ufficio contemporaneo, l'eleganza della base in legno calda ed accogliente perfetta per la casa e per gli ambienti contract.

La sua particolarità si legge nel profilo laterale marcato dalle cuciture a contrasto che ne evidenziano le forme. Le mille e una sagoma della seduta Rialtina riflettono le mille e le tante configurazioni naturali delle isole omonime, la Venezia degli albori. Da questo concept nasce Rialtina, una comoda e personalizzabile poltroncina dalle molteplici varianti.

→ EN Upholstered armchair with slim and firm features yet with comfortable and soft padding. Available either with or without armrests, the family of armchairs can be mounted on a wide range of bases in order to accommodate every occasion: the sled or the swivel base is suitable for the hybrid spaces of the contemporary offices; the more elegant wooden frame gives a warm and cosy feeling, perfect for the comfort of the house or for contract environments. Its particularity lies on its distinctive contours and contrast stitching that enhance its shape.

The thousand and one silhouettes of the Rialtina chair reflect the thousand and many natural configurations of the namesake islands, the dawn of Venice. Rialtina was born after this concept, a comfortable and customisable armchair with multiple variants.









→ IT La sedia in legno, ispirata alle sedute classiche dell'Ottocento con paglia di Vienna, riprende l'artigianalità italiana nella lavorazione del legno in una forma contemporanea. Le gambe lineari e coniche incontrano la morbidezza dello schienale e del sedile in paglia di Vienna, in multistrato oppure imbottito, per permettere flessibilità di finiture e colori. Caorlina nasce come barca popolare, multifunzionale ed efficiente. Agile, capiente, simmetrica: una struttura conservata nel tempo. È proprio la simmetria a determinare il concept riproposto in questa seduta, diventando un elogio all'imbarcazione che collega le isole alla terraferma.

→ EN The wooden chair, inspired by the classical seats of the '800 featuring woven cane, recalls the Italian craftsmanship of woodworking with a contemporary twist. The linear and conical legs meet the smoothness of the backrest and the seat in woven cane, plywood or padding, which allows one to customise the chair as he pleases for further flexibility of colours and finishes. Caorlina was born as a popular, multifunctional and efficient boat. Agile, spacious, symmetrical: a structure preserved overtime. It is precisely this symmetry that determines the concept presented in this chair which becomes a tribute to the boat that connects the islands to the mainland.







→ IT La collezione TAXI è ispirata alla forma del mezzo di trasporto acquatico attraverso le atmosfere che si possono cogliere navigando tra le calli. Il telaio in tubolare, sapientemente curvato da maestranze locali, accoglie e sostiene lo schienale e la seduta di poltroncina, sgabello e sedia, con una varietà di finiture e materiali di pregio. Il taxi veneziano è uno dei riferimenti della mobilità lagunare ed è un simbolo internazionale di stile, eleganza e cura nei materiali.

→ EN The TAXI collection is inspired by this mode of water transportation's shape and captures the spirit aboard, navigating through the city's streets and alleyways. The tubular frame has been skilfully formed by the experienced hands of local artisans to accommodate and support the backrest and seat of the lounge chair, stool and chair, available in a variety of fine finishes and materials. Venetian Taxis are one of the flagships of the transport system in the Lagoon, and an internationally recognised symbol of style, elegance and attention to details.

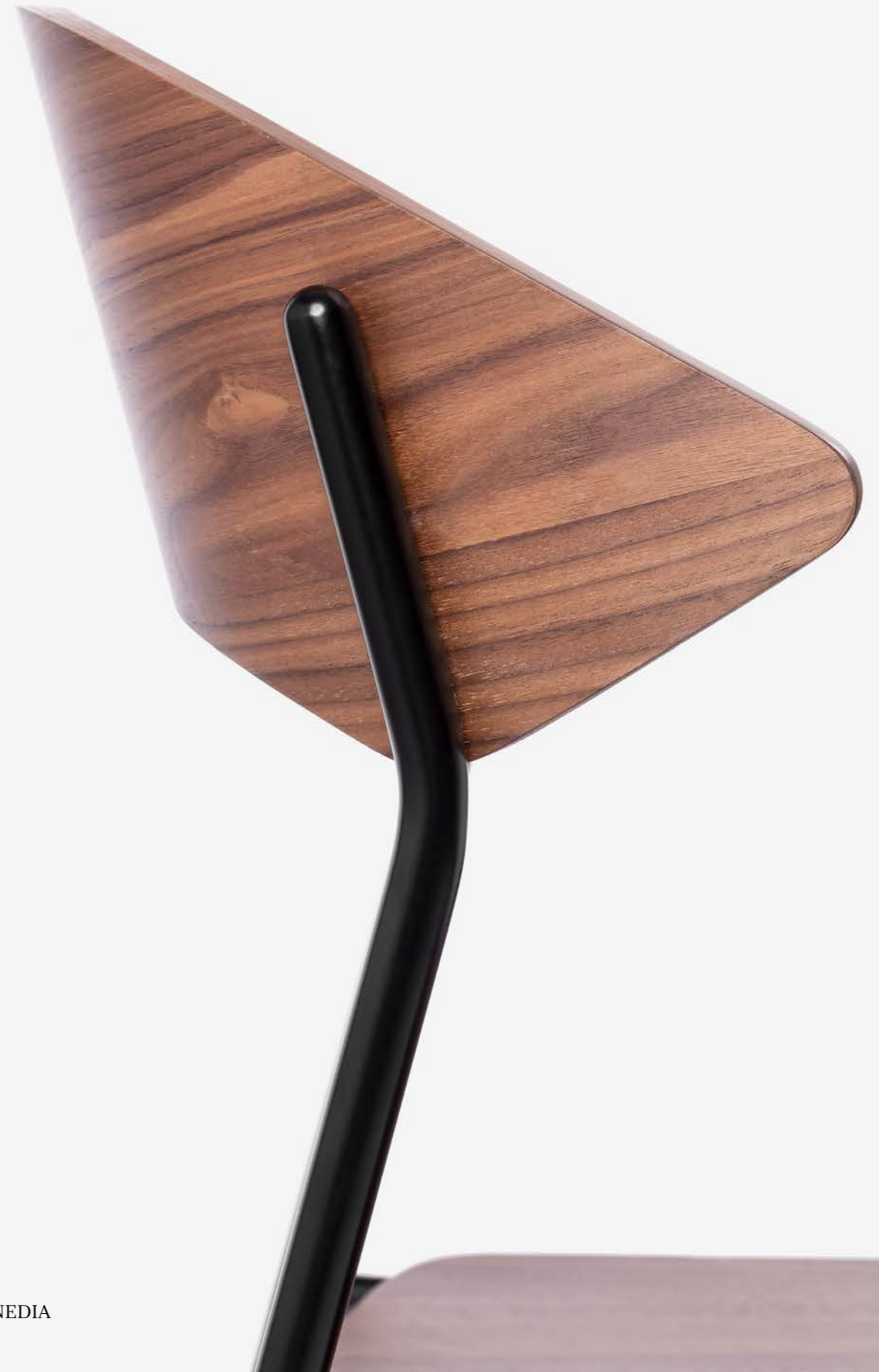

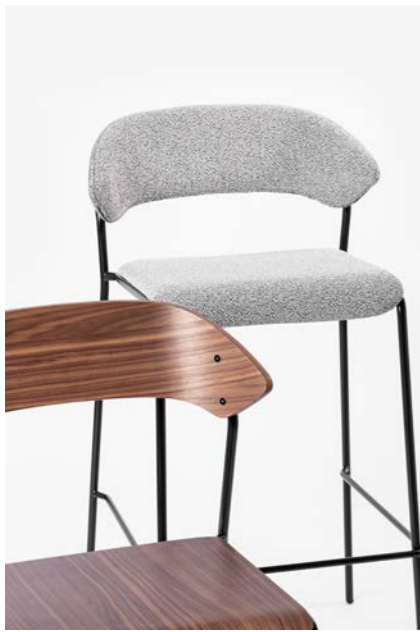



→ IT Come se stesse fluttuando, il piano poggia elegantemente sulla struttura: Parón è una collezione di tavoli disponibile in diverse basi e finiture. La sospensione del piano rispetto alla struttura dona al tavolo robusto la sua leggerezza, addolcita dagli angoli arrotondati.

La struttura con gambe in legno richiama gli ambienti confortevoli della casa, evidenziandone il ruolo centrale negli ambienti domestici. La struttura in metallo, dal design compatto ed elegante, si presta perfettamente sia ad un arredamento residenziale che contract. Svetta su Venezia El Parón de Casa, il Campanile di San Marco. Robustezza, solidità e maestosità sono le caratteristiche che il tavolo Parón rispecchia, divenendo El Parón delle vostre case.

→ EN Almost as if it were floating, the top lies gracefully on the frame: Parón is a table collection available in different structures and finishes.

The separation between the table top and the leg structure is what gives the robust table its light appearance, softened by its round edges. The wooden leg structure recalls the cosy environment of the house, becoming the focal point of the household. The metal frame, with its elegant yet solid design, is perfectly suited for both residential and contract décor. "The master of the house" (el parón de casa) towers over the city of Venice: it is the St Mark's bell tower. Sturdiness, solidity and majesty are the characteristics that the Parón table replicates, becoming the master (el parón) of your home.











→ IT Ciacola è una collezione di tavoli da bar e da pranzo disponibile in varie misure ed altezze. Le gambe richiamano la forma delle briccole veneziane formate da tre o più pali di legno legati tra loro da un anello metallico. La base in tubo, dal design essenziale ed equilibrato, si adatta perfettamente agli ambienti bar o esterni; la base in legno a 4 gambe, accogliente, si sposa con la comodità della casa. Il piano sottile in differenti finiture dona leggerezza al tavolo, mentre il piano in legno, con la sua variazione di colore che riprende l'anello, spezza l'altresì monocromia. Gli amici fidati si riuniscono attorno ad un tavolo per una ciacola, la tipica chiacchiera veneziana, così come i semplici pali in legno della briccola sono uniti fra loro da un anello metallico. La struttura di Ciacola Table si ispira alla briccola, elemento presente nella laguna, guida fidata e indice della via d'acqua navigabile, ottenendo un comodo tavolo dove condividere le ciacole quotidiane.

→ EN Ciacola is a table collection available in different heights and measurements. The table legs recall the shape of the venetian briccola, three wooden poles tied together by a metal ring. The tubular frame, with its essential and balanced design suits perfectly into bar spaces or outdoors; the wooden frame on the other hand, elegant yet cosy, goes hand in hand with the comfort of the house. The slim table top that gives the product its lightness is available in a variety of finishes, while the wooden top breaks the otherwise monochromy. Close friends gather around a table for a ciacola, the typical Venetian chat, just like the wooden poles of the briccola are gathered together by a metal ring. The frame of the Ciacola Table is inspired by the briccola, an ever-present element in the lagoon, a reliable guide and indicator of waterways, resulting in a comfortable table where everyday ciacolas can be shared.

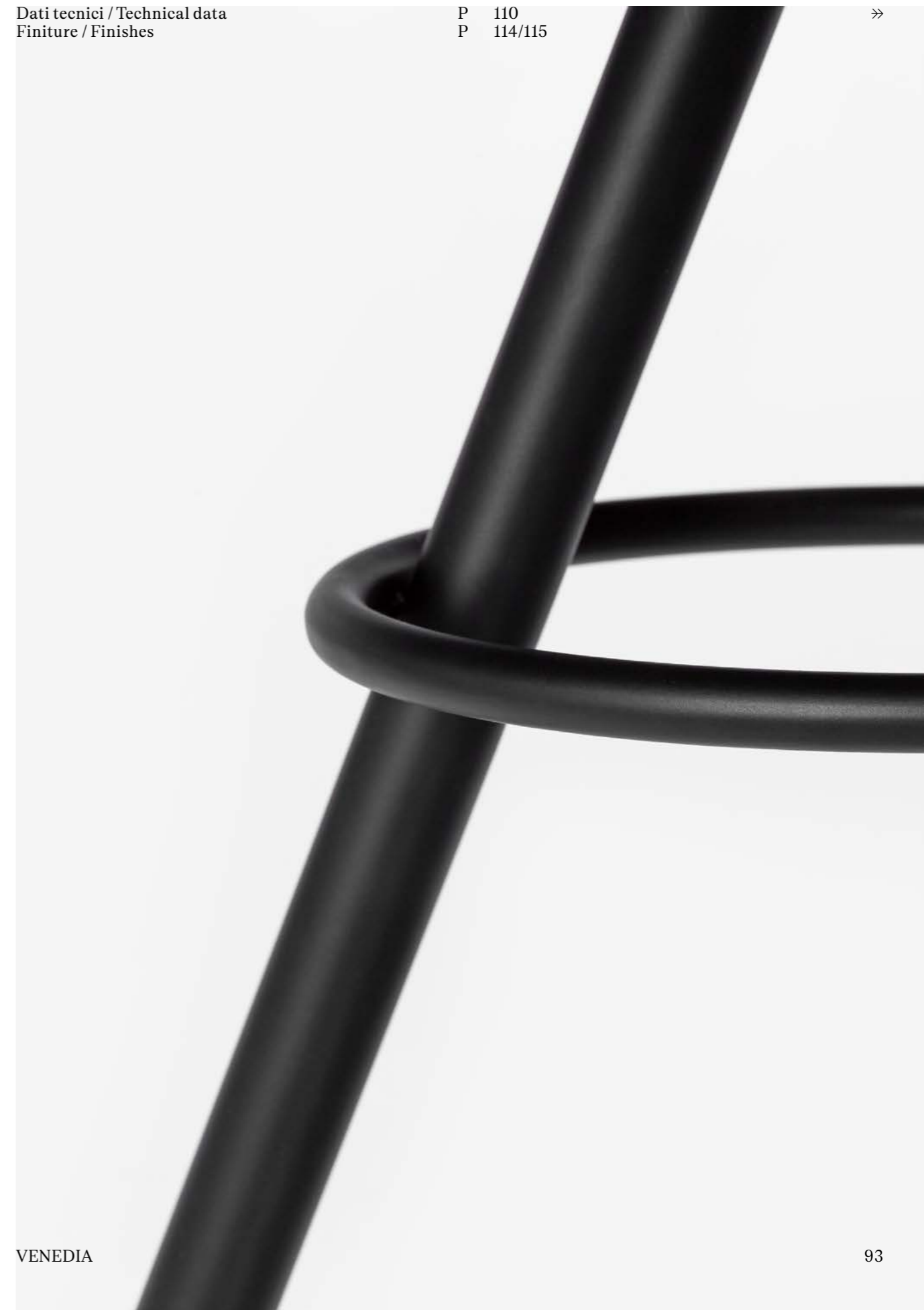





→ IT Le gambe dei tavoli in legno vengono avvolte a elica da strisce di acciaio verniciato, applicate a secco senza ausilio di collanti e bloccate meccanicamente. Il risultato è un'alternanza cromatica e materica elegante ed esclusiva, capace di trasmettere l'unicità del prodotto Made in Italy. I prodotti della collezione PALINA sono disponibili in diversi formati e accostamenti cromatici.

Un palo da ormeggio isolato che svetta a raso sulle acque lagunari, la palina è uno dei simboli iconici veneziani che ritroviamo tra i canali e le calli a cui diamo meno importanza - ma visivamente ricordiamo tutti.

→ EN The wooden table legs are wrapped with painted steel spirals, dry-applied without using adhesives and fixed in place. The result is an exclusive, elegant design with alternating colours and materials that perfectly expresses the unique qualities of made-in-Italy products. The PALINA collection comes in different shapes and colour combinations.

A lone mooring post stands tall in the lagoon waters, flush to its fluid surface: the PALINA, as it's known in the Venetian lingo. It's one of the iconic symbols of Venice, found along the city's many streets and canals. We perhaps don't always appreciate they're there, but it's hard to forget what they look like.

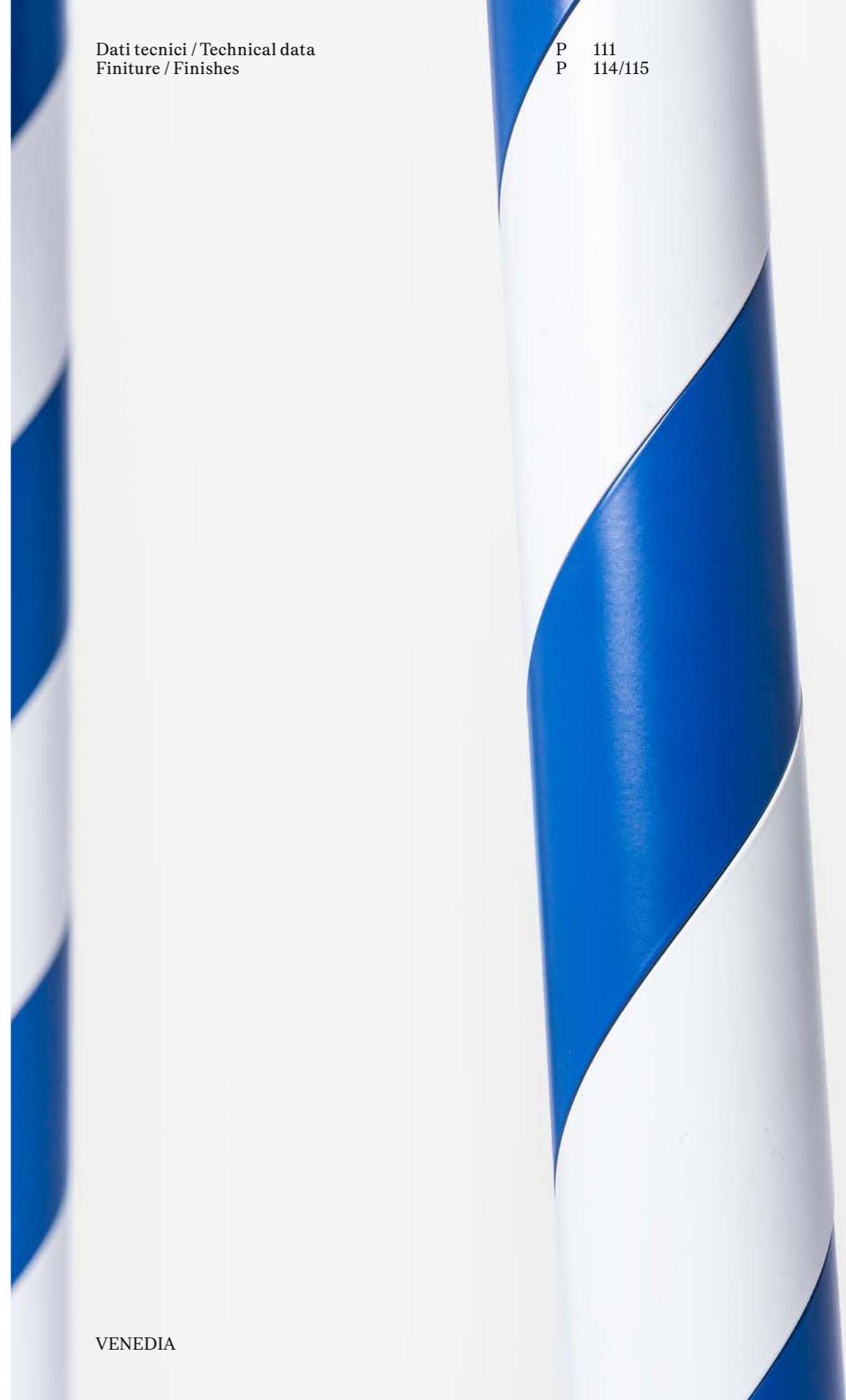



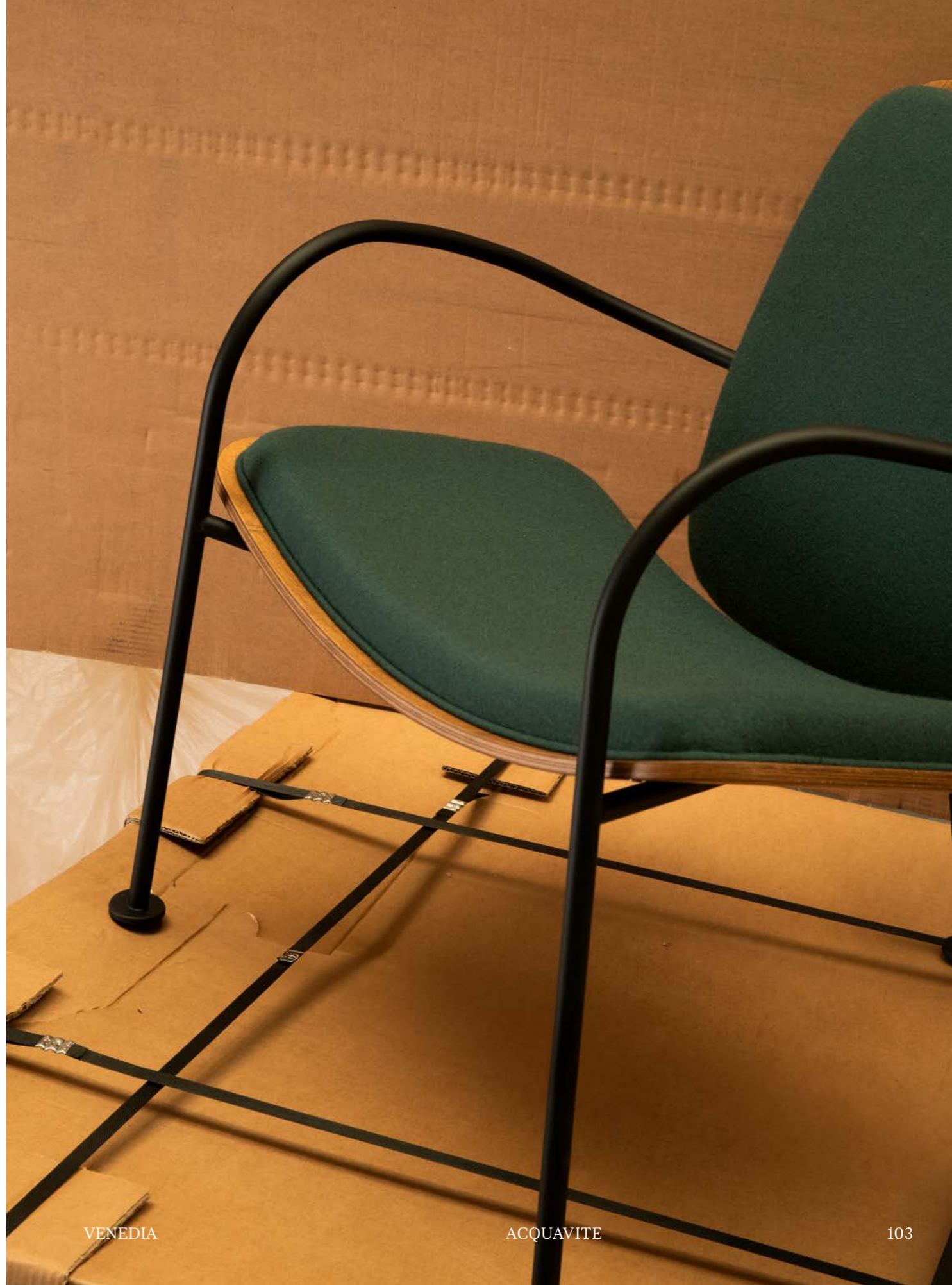



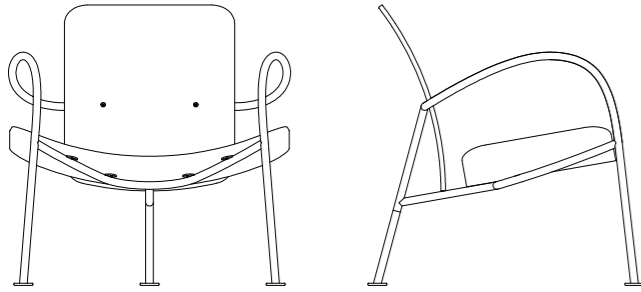

ACQUAVITE
Poltroncina in multistrato di frassino, senza imbottitura. Struttura in metallo.
Peso 12 kg
Misure 72x73x75 cm
– h seduta 44 cm
Imballo 1x1 pz cm 75x75x80 h
Tessuto v. pag. 112/113
Legni v. pag. 115
cod. 00, 02, 60
Verniciatura v. pag. 114
cod. 9005, 9010

Lounge chair in ash-veneered plywood, without padding. Metal base.
Weight 12 kg
Dimensions 72x73x75 cm
– seat height 44 cm
Packaging 1x1 pz cm 75x75x80 h
Fabrics see page 112/113
Veneered see page 115
00, 02, 60
Finish see page 114
cod. 9005, 9010

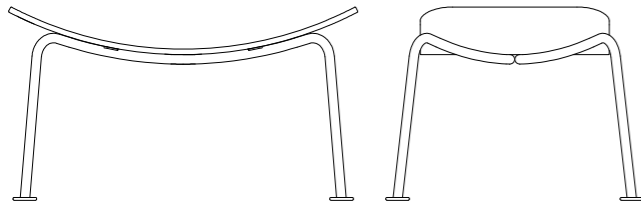

ACQUAVITE
Ottomana in multistrato di frassino, senza imbottitura. Struttura in metallo.
Peso 5 kg
Misure 74x55x44 cm
Imballo 1x1 pz cm 75x75x50 h
Tessuto v. pag. 112/113
Legni v. pag. 115
cod. 00, 02, 60
Verniciatura v. pag. 114
cod. 9005, 9010

Ottoman in ash-veneered plywood, without padding. Metal base.
Weight 5 kg
Dimensions 74x55x44 cm
Packaging 1x1 pz cm 75x75x50 h
Fabrics see page 112/113
Veneered see page 115
00, 02, 60
Finish see page 114
cod. 9005, 9010

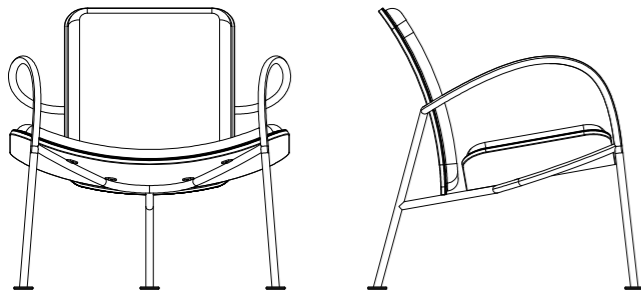

ACQUAVITE
Poltroncina in multistrato di frassino, con imbottitura. Struttura in metallo.
Peso 12 kg
Misure 72x73x75 cm
– h seduta 44 cm
Imballo 1x1 pz cm 75x75x80 h
Tessuto v. pag. 112/113
Legni v. pag. 115
cod. 00, 02, 60
Verniciatura v. pag. 114
cod. 9005, 9010

Lounge chair in ash-veneered plywood, with padding. Metal base.
Weight 12 kg
Dimensions 72x73x75 cm
– seat height 44 cm
Packaging 1x1 pz cm 75x75x80 h
Fabrics see page 112/113
Veneered see page 115
00, 02, 60
Finish see page 114
cod. 9005, 9010

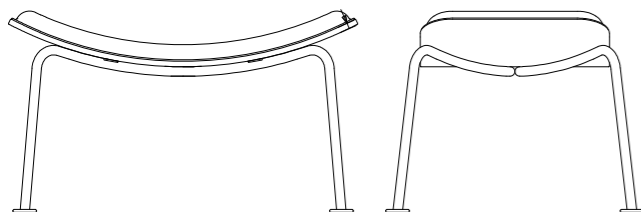

ACQUAVITE
Ottomana in multistrato di frassino, con imbottitura. Struttura in metallo.
Peso 5 kg
Misure 74x55x44 cm
Imballo 1x1 pz cm 75x75x50 h
Tessuto v. pag. 112/113
Legni v. pag. 115
cod. 00, 02, 60
Verniciatura v. pag. 114
cod. 9005, 9010

Ottoman in ash-veneered plywood, with padding. Metal base.
Weight 5 kg
Dimensions 74x55x44 cm
Packaging 1x1 pz cm 75x75x50 h
Fabrics see page 112/113
Veneered see page 115
00, 02, 60
Finish see page 114
cod. 9005, 9010

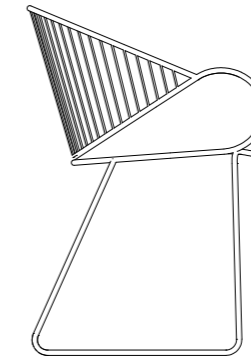
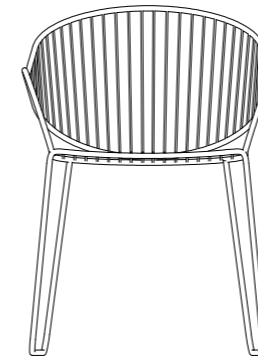

CELESTIA
Sedia da esterno Poltroncina in tondino di metallo
Peso 8 kg
Misure 53.6x47.5x80 cm
– h seduta 45 cm
Imballo 1x1 pz cm 60x52x85 h
Verniciatura v. pag. 114
cod. 1019, 3004, 6012

Outdoor chair
Metal wire armchair
Weight 8 kg
Dimensions 53.6x47.5x80 cm
– seat height 45 cm
Packaging 1x1 pz cm 60x52x85 h
Finish see page 114
cod. 1019, 3004, 6012

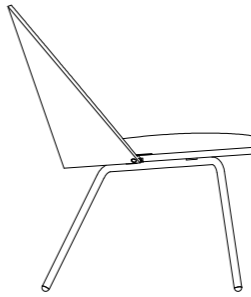

SANPOLO
Poltroncina in multistrato impiallacciato o imbottito, struttura in metallo.
Peso 7 kg
Misure 68x69x76 cm
– h seduta 42 cm
Imballo 1x1 pz cm 75x75x80 h
Tessuto v. pag. 112/113
Legni v. pag. 115
cod. 00, 02, 05
Verniciatura v. pag. 114
cod. 9005, 9010

Lounge chair in veneered or padded plywood. Metal base.
Weight 7 kg
Dimensions 68x69x76 cm
– seat height 42 cm
Packaging 1x1 pz cm 75x75x80 h
Fabrics see page 112/113
Veneers see page 115
00, 02, 05
Finish see page 114
cod. 9005, 9010

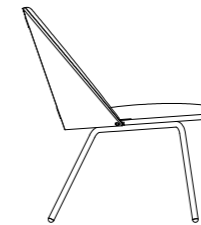
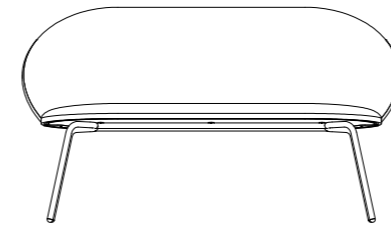

SANPOLO
Divanetto in multistrato imbottito, struttura in metallo.
Peso 16 kg
Misure 130x69x76 cm
– h seduta 42 cm
Imballo 1x1 pz cm 135x75x80 h
Tessuto v. pag. 112/113
Verniciatura v. pag. 114
cod. 9005, 9010

Lounge sofa in padded plywood. Metal base.
Weight 16 kg
Dimensions 130x69x76 cm
– seat height 42 cm
Packaging 1x1 pz cm 135x75x80 h
Fabrics see page 112/113
Finish see page 114
cod. 9005, 9010

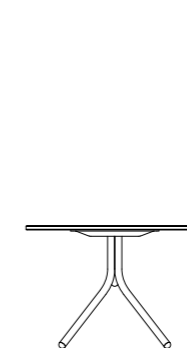
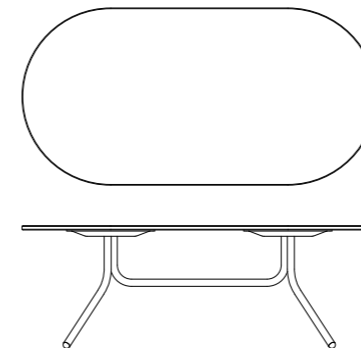

SANPOLO
Tavolino con top in hpl o fenix, struttura in metallo.
Peso 4 kg
Misure 100x50x35 h cm
Imballo 1x1 pz cm 105x55x40 h
Piani v. pag. 115
cod. 0249, 0509, 3476, 3326, 0720
Verniciatura see page 114
cod. 9005, 9010

Low table with hpl or Fenix table top, metal base.
Weight 4 kg
Dimensions 100x50x35 h cm
Packaging 1x1 pz cm 105x55x40 h
Top see page 115
cod. 0249, 0509, 3476, 3326, 0720
Finish see page 114
cod. 9005, 9010

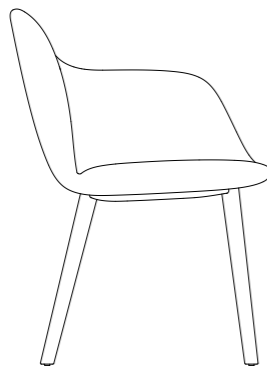
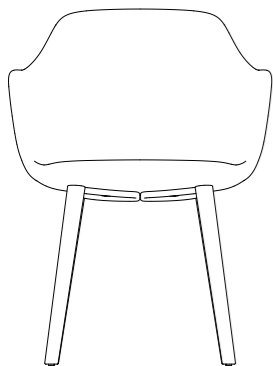
**RIALTINA**

Poltroncina con braccioli, gambe in legno. Schiumato di poliuretano espanso flessibile con inserto in metallo.
 Peso 8.5 kg
 Misure 59.6x59.1x80x8 cm – h seduta 46.5 cm
 Imballo 1x1 pz cm 65.5x65x85 h
 Tessuti v. pag 112/113
 Legni v. pag 115
 COD. 00, 02

Armchair with armrests, wooden legs. Steel frame padded with flexible polyurethane foam.
 Weight 8.5 kg
 Dimensions 59.6x59.1x80x8 cm – seat h 46.5 cm
 Packaging 1x1 pz cm 65.5x65x85 h
 Fabrics see page 112/113
 Legs see page 115
 COD. 00, 02

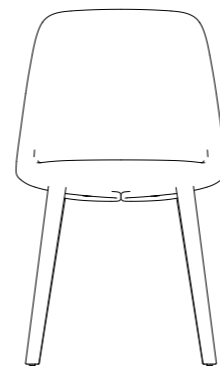
**RIALTINA**

Seduta, gambe in legno. Schiumato di poliuretano espanso flessibile con inserto in metallo.
 Peso 7.5 kg
 Misure 47.4x59.1x80,8 cm – h seduta 46.5 cm
 Imballo 1x1 pz cm 65.5x65x85 h
 Tessuti v. pag 112/113
 Legni v. pag 115
 cod. 00, 02

Armchair, wooden legs. Steel frame padded with flexible polyurethane foam.
 Weight 7.5 kg
 Dimensions 47.4x59.1x80,8 cm – seat h 46.5 cm
 Packaging 1x1 pz cm 65.5x65x85 h
 Fabrics see page 112/113
 Legs see page 115
 cod. 00, 02

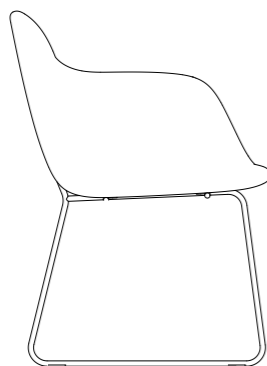
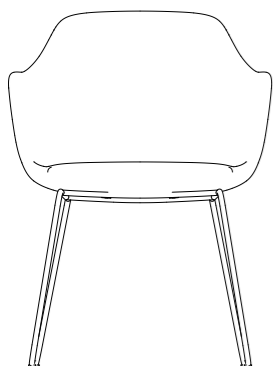
**RIALTINA**

Poltroncina con braccioli, slitta in metallo. Schiumato di poliuretano espanso flessibile con inserto in metallo.
 Peso 10 kg
 Misure 59.6x59.1x80x8 cm – h seduta 46.5 cm
 Imballo 1x1 pz cm 65.5x65x85 h
 Tessuti v. pag 112/113
 Verniciatura v. pag 114
 cod. 9005, 9010

Armchair with armrests, metal sled. Steel frame padded with flexible polyurethane foam.
 Weight 10 kg
 Dimensions 59.6x59.1x80x8 cm – seat h 46.5 cm
 Packaging 1x1 pz cm 65.5x65x85 h
 Fabrics see page 112/113
 Finish see page 114
 cod. 9005, 9010

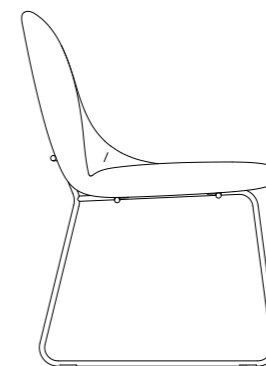
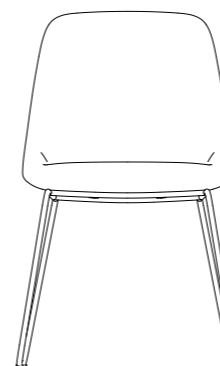
**RIALTINA**

Seduta, slitta in metallo. Schiumato di poliuretano espanso flessibile con inserto in metallo.
 Peso 9 kg
 Misure 47.4x59.1x80,8 cm – h seduta 46.5 cm
 Imballo 1x1 pz cm 65.5x65x85 h
 Tessuti v. pag 112/113
 Verniciatura v. pag 114
 cod. 9005, 9010

Armchair, wooden legs. Steel frame padded with flexible polyurethane foam.
 Weight 9 kg
 Dimensions 47.4x59.1x80,8 cm – seat h 46.5 cm
 Packaging 1x1 pz cm 65.5x65x85 h
 Fabrics see page 112/113
 Legs see page 114
 cod. 9005, 9010

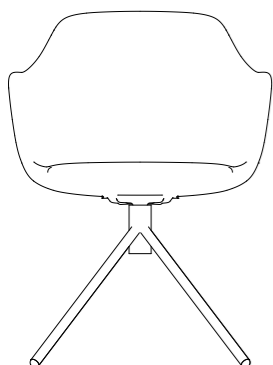
**RIALTINA**

Poltroncina con braccioli, 4 razze. Schiumato di poliuretano espanso flessibile con inserto in metallo.
 Peso 9.5 kg
 Misure 59.6x59.1x80x8 cm – h seduta 46.5 cm
 Imballo 1x1 pz cm 65.5x65x85 h
 Tessuti v. pag 112/113
 Verniciatura v. pag 114
 cod. 9005, 9010

Armchair with armrests, 4-star swivel base. Steel frame padded with flexible polyurethane foam.
 Weight 9.5 kg
 Dimensions 59.6x59.1x80x8 cm – seat h 46.5 cm
 Packaging 1x1 pz cm 65.5x65x85 h
 Fabrics see page 112/113
 Finish see page 114
 cod. 9005, 9010

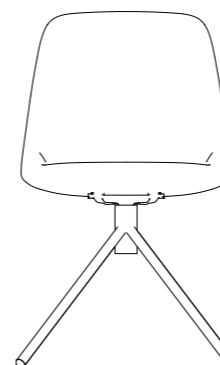
**RIALTINA**

Seduta, 4 razze. Schiumato di poliuretano espanso flessibile con inserto in metallo.
 Peso 8.5 kg
 Misure 59.6x59.1x80x8 cm – h seduta 46.5 cm
 Imballo 1x1 pz cm 65.5x65x85 h
 Tessuti v. pag 112/113
 Verniciatura v. pag 114
 cod. 9005, 9010

Armchair, 4-star swivel base. Steel frame padded with flexible polyurethane foam.
 Weight 8.5 kg
 Dimensions 59.6x59.1x80x8 cm – seat h 46.5 cm
 Packaging 1x1 pz cm 65.5x65x85 h
 Fabrics see page 112/113
 Finish see page 114
 cod. 9005, 9010

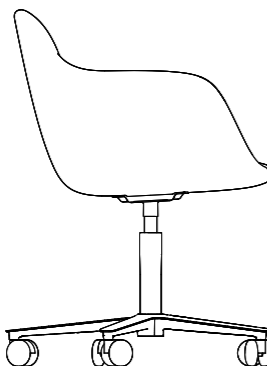
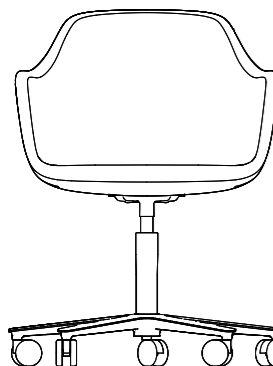
**RIALTINA**

Poltroncina con braccioli, 5 razze. Schiumato di poliuretano espanso flessibile con inserto in metallo.
 Peso 10.5 kg
 Misure 62.8x62.8x80x8 cm – h seduta regolabile
 Imballo 1x1 pz cm 65.5x65x85 h
 Tessuti v. pag 112/113
 Verniciatura v. pag 114
 cod. 9005

Armchair with armrests, 5-star swivel base. Steel frame padded with flexible polyurethane foam.
 Weight 10.5 kg
 Dimensions 62.8x62.8x80x8 cm – adjustable seat h
 Packaging 1x1 pz cm 65.5x65x85 h
 Fabrics see page 112/113
 Finish see page 114
 cod. 9005

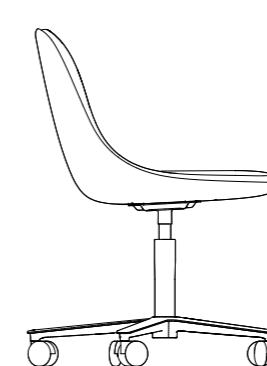
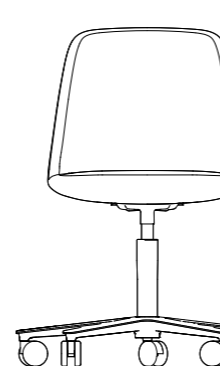
**RIALTINA**

Seduta, 5 razze. Schiumato di poliuretano espanso flessibile con inserto in metallo.
 Peso 9.5 kg
 Misure 62.8x62.8x80x8 cm – h seduta regolabile
 Imballo 1x1 pz cm 65.5x65x85 h
 Tessuti v. pag 112/113
 Verniciatura v. pag 114
 cod. 9005

Armchair, 5-star swivel base. Steel frame padded with flexible polyurethane foam.
 Weight 9.5 kg
 Dimensions 62.8x62.8x80x8 cm – adjustable seat h
 Packaging 1x1 pz cm 65.5x65x85 h
 Fabrics see page 112/113
 Finish see page 114
 cod. 9005

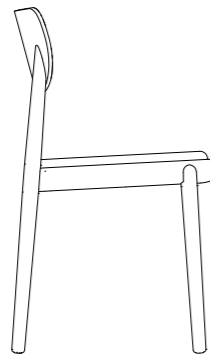
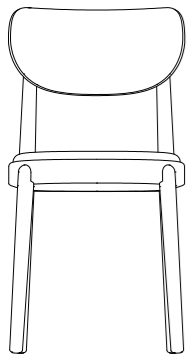
**CAORLINA**

Sedia, imbottita.
Sedia in faggio con schienale in multistrato. Verniciatura a base acqua, finitura opaca.
Peso 4,8 kg
Misure 41,6x45,8x81,3 cm
- h seduta 44,2 cm
Imballo 1x2 pz cm 52x57,5x100 h
Tessuti v. pag 112/113
Verniciatura v. pag 114
cod. 00, 10, 05, 60

Chair, padded.
Beech chair with plywood backrest. Water-based varnish, matte finish.
Weight 4,8 kg
Dimensions 41,6x45,8x81,3 cm
- seat height 44,2 cm
Packaging 1x2 pz cm 52x57,5x100 h
Fabrics see page 112/113
Finish see page 114
cod. 00, 10, 05, 60

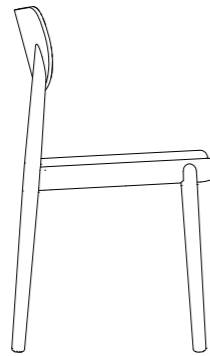
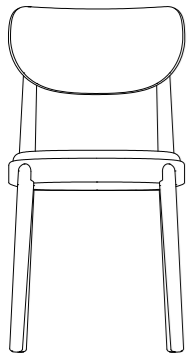
**CAORLINA**

Sedia, paglia di Vienna.
Sedia in faggio con schienale in multistrato. Verniciatura a base acqua, finitura opaca.
Peso 4,6 kg
Misure 41,6x45,8x81,3 cm
- h seduta 44,2 cm
Imballo 1x2 pz cm 52x57,5x100 h
Verniciatura v. pag 114
cod. 00, 10, 05, 60

Chair, woven cane.
Beech chair with plywood backrest. Water-based varnish, matte finish.
Weight 4,6 kg
Dimensions 41,6x45,8x81,3 cm
- seat height 44,2 cm
Packaging 1x2 pz cm 52x57,5x100 h
Finish see page 114
cod. 00, 10, 05, 60

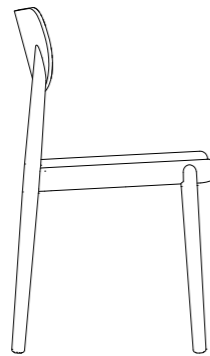
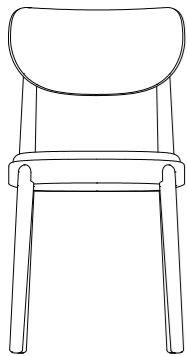
**CAORLINA**

Sedia, multistrato.
Sedia in faggio con schienale in multistrato. Verniciatura a base acqua, finitura opaca.
Peso 4,7 kg
Misure 41,6x45,8x81,3 cm
- h seduta 44,2 cm
Imballo 1x2 pz cm 52x57,5x100 h
Verniciatura v. pag 114
cod. 00, 10, 05, 60

Chair, plywood.
Beech chair with plywood backrest. Water-based varnish, matte finish.
Weight 4,7 kg
Dimensions 41,6x45,8x81,3 cm
- seat height 44,2 cm
Packaging 1x2 pz cm 52x57,5x100 h
Finish see page 114
cod. 00, 10, 05, 60

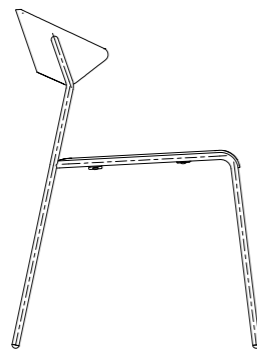
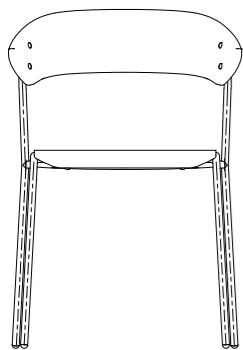
**TAXI_C sedia**

Seduta e schienale in multistrato impiallacciato o imbottito, struttura in metallo. Impilabile.
Peso 5 kg
Misure 53x56x77cm
- h seduta 45 cm
Imballo 1x2 pz cm 66x54x86 h
Tessuti v. pag 112/113
Legni v. pag. 115
00, 02
Verniciatura v. pag 114
cod. 9005, 9010

TAXI_C chair

Seat and backrest in veneered or padded plywood. Stackable.
Weight 5 kg
Dimensions 53x56x77cm
- seat height 45 cm
Packaging 1x2 pz cm 66x54x86 h
Fabrics see page 112/113
Veneered see page 115
00, 02
Finish see page 112/113
cod. 9005, 9010

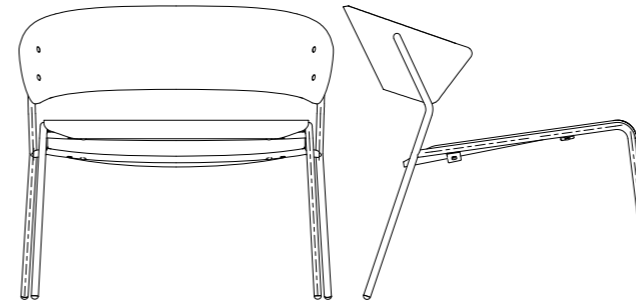

TAXI_L poltroncina
Seduta e schienale in multistrato impiallacciato o imbottito, struttura in metallo. Impilabile.
Peso 7,7 kg
Misure 71x66x67cm
- h seduta 40 cm
Imballo 1x2 pz cm 73x71x75 h
Tessuti v. pag 112/113
Legni v. pag. 115
00, 02
Verniciatura v. pag 114
cod. 9005, 9010

TAXI_L lounge chair
Seat and backrest in veneered or padded plywood. Stackable.
Weight 7,7 kg
Dimensions 71x66x67cm
- seat height 40 cm
Packaging 1x2 pz cm 73x71x75 h
Fabrics see page 112/113
Veneered see page 115
00, 02
Finish see page 114
cod. 9005, 9010

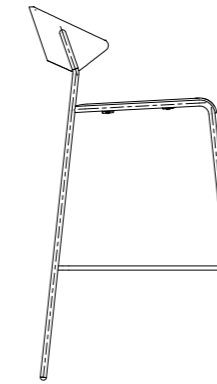
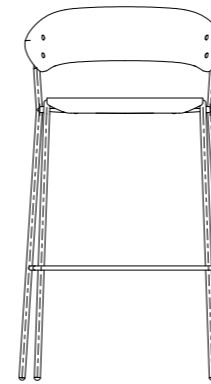

TAXI_S sgabello
Seduta e schienale in multistrato impiallacciato o imbottito, struttura in metallo. Impilabile.
Peso 7,75 kg
Misure 54x53x88cm - h seduta 65 cm / 54x53x98cm - h seduta 75 cm
Imballo 1x2 pz cm 61x54x105 h
Tessuti v. pag 112/113
Legni v. pag. 115
00, 02
Verniciatura v. pag 114
cod. 9005, 9010

TAXI_S sgabello
Seat and backrest in veneered or padded plywood. Stackable.
Weight: 7,75 kg
Dimensions 54x53x88cm - seat height 65 cm / 54x53x98cm - seat height 75 cm
Packaging 1x2 pz cm 61x54x105 h
Fabrics see page 112/113
Veneered see page 115
00, 02
Finish see page 114
cod. 9005, 9010

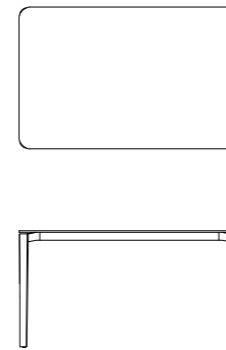
**PARÓN**

Tavolo pranzo fisso, base legno o metallo. Piano di spessore 10 mm.
Peso base metallo 31 kg / base legno 29 kg
Misure 140x90x74 h
Imballo: 3 pz cm 145x95x12 cm / 74x95x35 cm / 120x6x6 cm
Top v. pag. 115 cod. 0249, 0509, 3476, 3326, 0720
Legni v. pag. 115 cod. 00
Verniciatura: v. pag 114
cod. 9005, 9010

Fixed dining table, metal or wooden legs, 10 mm thickness table top.
Weight metal base 31 kg / wooden base 29 kg
Dimensions 140x90x74 h
Packaging 3 pz cm 145x95x12 cm / 74x95x35 cm / 120x6x6 cm
Top see page 115 cod. 0249, 0509, 3476, 3326, 0720
Legs see page 115 cod. 00
Finish see page 114
cod. 9005, 9010

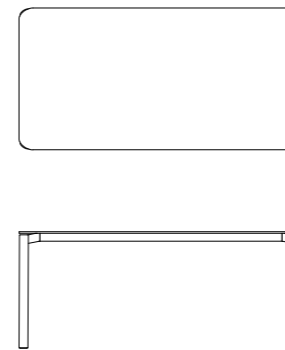
**PARÓN**

Tavolo pranzo fisso, base legno o metallo. Piano di spessore 10 mm.
Peso base metallo 40 kg / base legno 38 kg
Misure 180x90x74 h
Imballo 3 pz cm 185x95x12 cm / 74x95x35 cm / 160x6x6 cm
Top v. pag. 115 cod. 0249, 0509, 3476, 3326, 0720
Legni v. pag. 115 cod. 00
Verniciatura v. pag 114
cod. 9005, 9010

Fixed dining table, metal or wooden legs, 10 mm thickness table top.
Weight metal base 40 kg / wooden base 38 kg
Dimensions 180x90x74 h
Packaging 3 pz cm 185x95x12 cm / 74x95x35 cm / 160x6x6 cm
Top see page 115 cod. 0249, 0509, 3476, 3326, 0720
Legs see page 115 cod. 00
Finish see page 114
cod. 9005, 9010

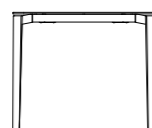
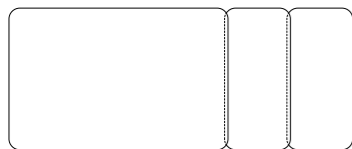

PARÓN
Tavolo pranzo allungabile, base legno o metallo. Piano di spessore 10 mm.
Peso base metallo 36 kg / base legno 34 kg
Misure 140+40+40x90x74 h
Imballo 3 pz cm 145x95x12 cm / 74x95x35 cm / 120x80x70 cm
Top v. pag. 115 cod. 0249, 0509, 3476, 3326, 0720
Legni v. pag. 115 cod. 00
Verniciatura v. pag 114 cod. 9005, 9010

Extendable dining table, metal or wooden legs, 10 mm thickness table top.
Weight metal base 36 kg / wooden base 34 kg
Dimensions 140+40+40x90x74 h
Packaging 3 pz cm 145x95x12 cm / 74x95x35 cm / 120x80x70 cm
Top see page 115 cod. 0249, 0509, 3476, 3326, 0720
Legs see page 115 cod. 00
Finish see page 114 cod. 9005, 9010

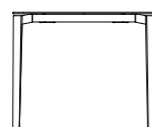
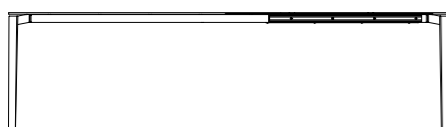
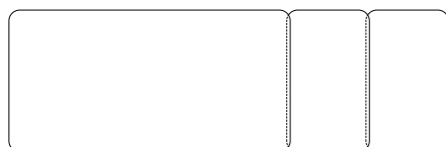

PARÓN
Tavolo pranzo allungabile, base legno o metallo. Piano di spessore 10 mm.
Peso: base metallo 46 kg / base legno 44 kg
Misure 180+50+50x90x74 h
Imballo: 3 pz cm 185x95x12 cm / 74x95x35 cm / 160x80x70 cm
Top v. pag. 115 cod. 0249, 0509, 3476, 3326, 0720
Legni v. pag. 115 cod. 00
Verniciatura v. pag 114 cod. 9005, 9010

Extendable dining table, metal or wooden legs, 10 mm thickness table top.
Weight metal base 46 kg / wooden base 44 kg
Dimensions 180+50+50x90x74 h
Packaging 3 pz cm 185x95x12 cm / 74x95x35 cm / 160x80x70 cm
Top see page 115 cod. 0249, 0509, 3476, 3326, 0720
Legs see page 115 cod. 00
Finish see page 114 cod. 9005, 9010

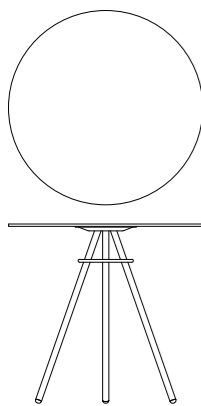

CIACOLA
Tavolo bar base metallo 3 o 4 gambe, Ø25 mm, altezza 73 o 110 cm. Piani di spessore 10 mm.
Peso 13 kg
Misure Ø79x74 cm / 72x72x74 cm / Ø60x110 cm
Imballo 2 pz cm 82x82x2 cm + 76x76 cm / 65x65x2 cm + 45x45x110 cm
Piano v. pag. 115 cod. 0249, 0509, 3476, 3326, 0720
Verniciatura v. pag. 114 cod. 9005, 9010

Bar table with a 3 or 4 leg metal base, Ø25 mm, height 73 or 110 cm. 10 mm thickness table tops.
Weight 13
Dimensions Ø79x74 cm / 72x72x74 cm / Ø60x110 cm
Packaging 2 pz cm 82x82x2 cm + 76x76 cm / 65x65x2 cm + 45x45x110 cm
Top see page 115 cod. 0249, 0509, 3476, 3326, 0720
Finish see page 114 cod. 9005, 9010

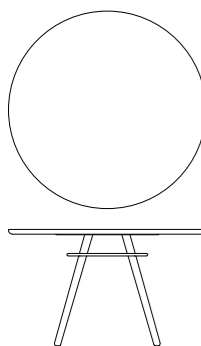

CIACOLA
Tavolo da pranzo circolare con top in MDF impiallacciato rovere con profilo a saponetta laccato.
Peso 22 kg
Misure Ø125x74 cm
Imballo 2 pz cm 130x130x6 cm / 70x70x74 cm
Piano v. pag. 115 cod. 0023, 0024
Verniciatura see page 114 cod. 00

Dining table with circular top in oak veneered MDF and lacquered soap bar shaped edges.
Weight 22 kg
Dimensions Ø125x74 cm
Packaging 2 pz cm 130x130x6 cm / 70x70x74 cm
Top see page 115 cod. 0023, 0024
Finish see page 114 cod. 00

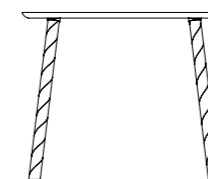

PALINA_R
Piano in MDF spessore 30 mm
Peso 27 kg
Misure 140x90x74 cm
Imballo 5 pz cm 146x96x4.5 h / 75.5x9.5x9.5 (4x)
Piano v. pag. 115 cod. 0249
Verniciatura v. pag. 114 cod. 9003+7030, 9003+9005, 9003+5005, 9003+3020, 1015+1013, 3004+3005, 9005+6012

Top in MDF width 30mm
Weight 27 kg
Dimensions 140x90x74 cm
Packaging 5 pz cm 146x96x4.5 h / 75.5x9.5x9.5 (4x)
Top see page 115 cod. 0249
Finish see page 114 cod. 9003+7030, 9003+9005, 9003+5005, 9003+3020, 1015+1013, 3004+3005, 9005+6012

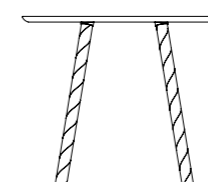
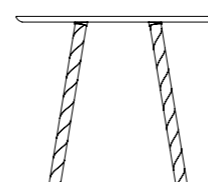
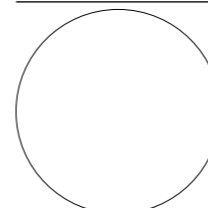

PALINA_C
Piano in MDF spessore 30 mm
Peso 15.5 kg
Misure Ø110x74 cm
Imballo 5 pz cm 116x116x4.5 h / 75.5x9.5x9.5 (4x)
Piano v. pag. 115 cod. 0249
Verniciatura v. pag 114 cod. 9003+7030, 9003+9005, 9003+5005, 9003+3020, 1015+1013, 3004+3005, 9005+6012

Top in MDF width 30mm
Weight 15.5 kg
Dimensions Ø110x74 cm
Packaging 5 pz cm 116x116x4.5 h / 75.5x9.5x9.5 (4x)
Top see page 115 cod. 0249
Finish see page 114 cod. 9003+7030, 9003+9005, 9003+5005, 9003+3020, 1015+1013, 3004+3005, 9005+6012

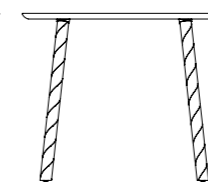
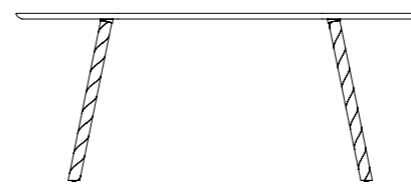

PALINA_O
Piano in MDF spessore 30 mm
Peso 31 kg
Misure 180x90x74 cm
Imballo 5 pz cm 186x96x4.5 h / 75.5x9.5x9.5 (4x)
Piano v. pag. 115 cod. 0249
Verniciatura v. pag 114 x cod. 9003+7030, 9003+9005, 9003+5005, 9003+3020, 1015+1013, 3004+3005, 9005+6012

Top in MDF width 30mm
Weight 31 kg
Dimensions 180x90x74 cm
Packaging 5 pz cm 186x96x4.5 h / 75.5x9.5x9.5 (4x)
Top see page 115 cod. 0249
Finish see page 114 cod. 9003+7030, 9003+9005, 9003+5005, 9003+3020, 1015+1013, 3004+3005, 9005+6012

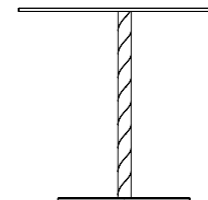
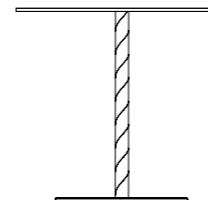
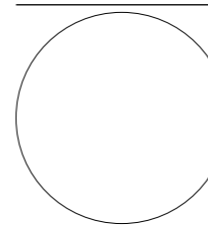

PALINA MONOGAMBA IN METALLO
Peso 15 kg
Misure Ø79x74 cm
Imballo 2 pz cm 82x82x2 cm / 20x20x75 cm
Piano v. pag. 115 cod. 0249, 0509, 3476, 3326, 0720
Verniciatura v. pag 114 cod. 9003+7030, 9003+9005, 9003+5005, 9003+3020, 1015+1013, 3004+3005, 9005+6012

PALINA SINGLE METAL LEG
Weight 15 kg
Dimensions Ø79x74 cm
Packaging 2 pz cm 82x82x2 cm / 20x20x75 cm
Top see page 115 cod. 0249, 0509, 3476, 3326, 0720
Finish see page 114 cod. 9003+7030, 9003+9005, 9003+5005, 9003+3020, 1015+1013, 3004+3005, 9005+6012



CAT.A

● Fidivi Jet
100% poliestere trevira CS
Martindale 65.000

Disponibile in 66 colori /
available in 66 colours

CAT.B



● Gabriel Focus
100% lana neozelandese
Martindale 100.000

Disponibile in 34 colori /
available in 34 colours



● Gabriel breeze fusion
88% lana neozelandese
12% poliammide
Martindale 100.000

Disponibile in 44 colori /
available in 44 colours



● Mam bouclè Rialto
46% CO 24% PC 13%
WV 11%VI 6% LI
Martindale 18.000

Disponibile in 11 colori /
available in 11 colours



● Mam velluto Lido
100% poliestere
Martindale 100.000

Disponibile in 23 colori /
available in 23 colours

CAT.C



● Rubelli 50shades
100% flame retardant PL
Martindale 80.000

Disponibile in 50 colori /
available in 50 colours



● Rubelli Fab30plus
100% flame retardant PL
Martindale 50.000

Disponibile in 60 colori /
available in 60 colours



● Rohi Sera 94%
WV 6% PA
Martindale 122.000

Disponibile in 26 colori /
available in 26 colours

CAT.D



● Kieffer Feral
14%WM 14%WO 28%
CO 36%PC 8%PA
Martindale 32.000

Disponibile in 13 colori /
available in 13 colours



● Rubelli Coriandoli s
100% flame retardant PL
Martindale 28.000

Disponibile in 8 colori /
available in 8 colours

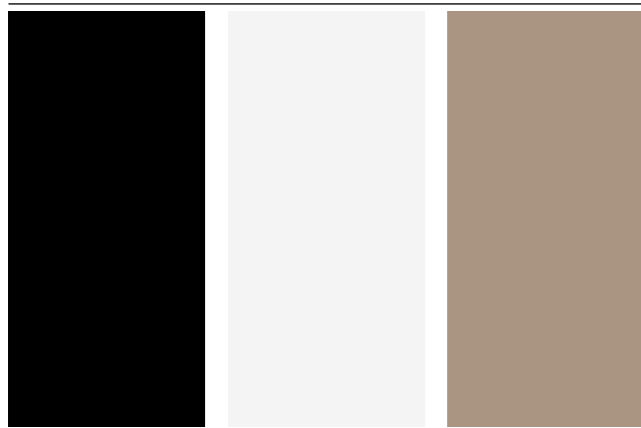

COD. 9005 COD. 9010 COD. 1019



COD. 3004 COD. 6012 COD. 7016

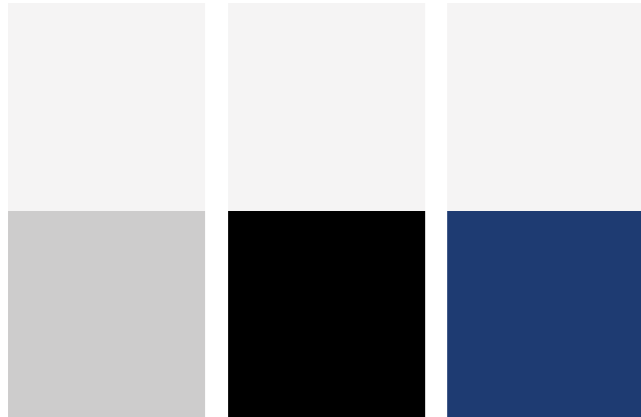

COD. 9003+7030 COD. 9003+9005 COD. 9003+5005

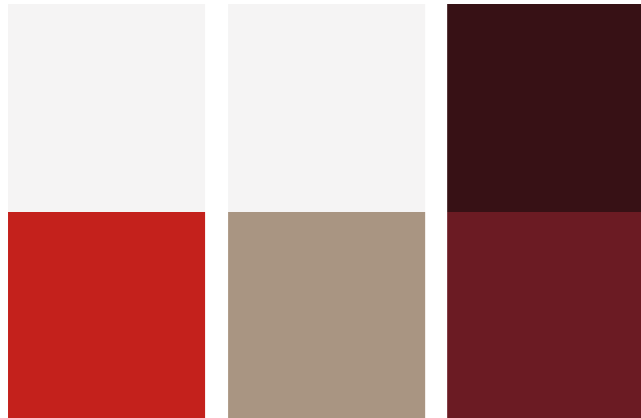

COD. 9003+3020 COD. 1015+1013 COD. 3004+3005 COD. 9005+6012

VERNICIATURE/
COATING FINISH

- Nero opaco /
Matte black
COD. 9005
- Bianco opaco /
Matte white
COD. 9010
- Tortora / Taupe
COD. 1019
- Rosso granata /
Grenade red
COD. 3004
- Verde foresta /
Forest green
COD. 6012
- Grigio antracite /
Charcoal grey
COD. 7016
- Bianco+grigio /
White+grey
COD. 9003+7030
- Bianco+nero /
White+black
COD. 9003+9005
- Bianco+blu /
White+blue
COD. 9003+5005
- Bianco+rosso /
White+red
COD. 9003+3020
- Bianco+beige /
White+beige
COD. 1015+1013
- Rosso+rosso / Red+red
COD. 3004+3005
- Verde+nero /
Green+black
COD. 9005+6012



COD. 00 COD. 02 COD. 10



COD. 05 COD. 60

LEGNO/ WOOD FINISH

- Naturale / Natural
COD. 00
- Tinto noce / Walnut
COD. 02
- Tinto bianco / White
COD. 10
- Tinto nero / Black
COD. 05
- Tinto verde / Green
COD. 60

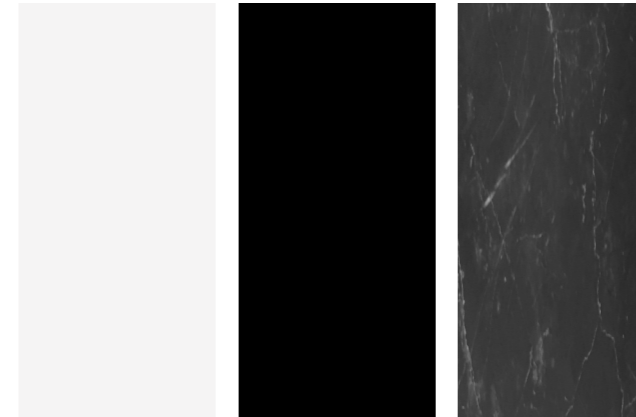

COD. 0249 COD. 0509 COD. 3476

TOPTAVOLI / TABLE
TOPS

- HPL bianco /
White HPL
COD. 0249
- HPL nero / Black HPL
COD. 0509
- HPL marmo nero /
Black marble hpl
COD. 3476
- HPL porfido /
Porphyry grey
COD. 3326
- Fenix nero / Black fenix
COD. 0720
- MDF rovere+bianco /
Oak+white MDF
COD. 0023
- MDF rovere+nero /
Oak+black MDF
COD. 0024

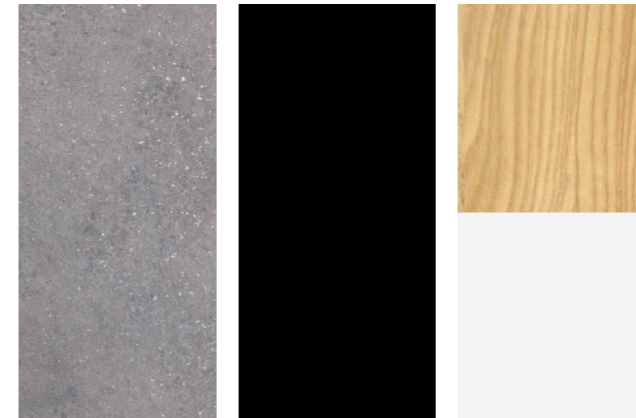

COD. 3326 COD. 0720 COD. 0023 COD. 0024













VENEDIA
Via C. Borsoi, 18 30023
Concordia Sagittaria (VE)
P.iva 03891420279
M info@venediadesign.com
T +39 0421 567690
W www.venediadesign.com

Art direction
Graphic design
Still-life photos
Staged photos
Styling (staged photos)
Renderings

Alessandro Stabile
Studio Iknoki
Fabrizia Parisi
Gaia Anselmi Tamburini
Andrea Bocca
Operaventuno

Venedia è un marchio registrato da Blutecnica srl
Venedia is a registered trademark by Blutecnica srl



ADIMEMBER

VENEDIA

MADE IN ITALY

Venetian heritage meets
contemporary design

VD

venediadesign.com